



INTERCOOLER PIPE INSTALL INSTRUCTIONS FOR 83-2005



PRINT

BEFORE YOU START

INTERCOOLER PIPE

VEHICLE FITMENT: 2023-2024 6.7L Powerstroke (high output only), Ford, F250/F350/F450

When removing any turbocharger air intake system components, make sure to cover any open ports to prevent any debris from entering the system. All components need to be inspected and cleaned (if necessary) prior to assembly and installation.

- Charge air cooler T-Bolt Hose Clamps making sure they are tight and secure.
- All electrical connections and wire harnesses moved during the installation of the charge air cooler pipe/hose and making sure they are secure and away from any hot or moving components.
- Check for any signs of abrasion or wear and tear on the charge air cooler hose, coolant hoses, power steering reservoir, power steering hoses, and electrical harnesses near the charge air cooler pipe/hose and repair/replace as necessary.

REQUIRED TOOLS

- 7mm, 10mm, Socket and Wrench
- 11mm Deep Socket
- 10" Socket Extension or 4" + 6" Socket Extensions
- Panel Popper
- Pick
- Small Flat Blade Screwdriver
- Wire Cutters
- Torque Wrench, 75 in-lb setting

Note: Approximate Install Time: 1 Hr 00 Mins for Kit Installation.



ITEM NO.	PART NUMBER	DESCRIPTION	83-2003	83-2004
REF. 1	AL3002-00	Hot Side CAC Pipe Welded Assembly, 83-2003	1	-
	AL3003-00	Hot Side CAC Pipe Welded Assembly, 83-2004	-	1
2	AI2886-00	3x5.5 Hump, 4-Ply Aramid Wrapped Silicone Hose	1	1
3	AG1042-00	T-Bolt Hose Clamp, Spring Loaded, 85.7-93.7mm	2	2
4	AI2796-00	3/16 width, Dash No. 332 Viton Fluoroelastomer O-Ring	1	1
5	AI2844-00	Spring Clip 83-2003/2004	1	1
6	AI2843-00	Pipe Clip, 83-2003/ 2004	1	1

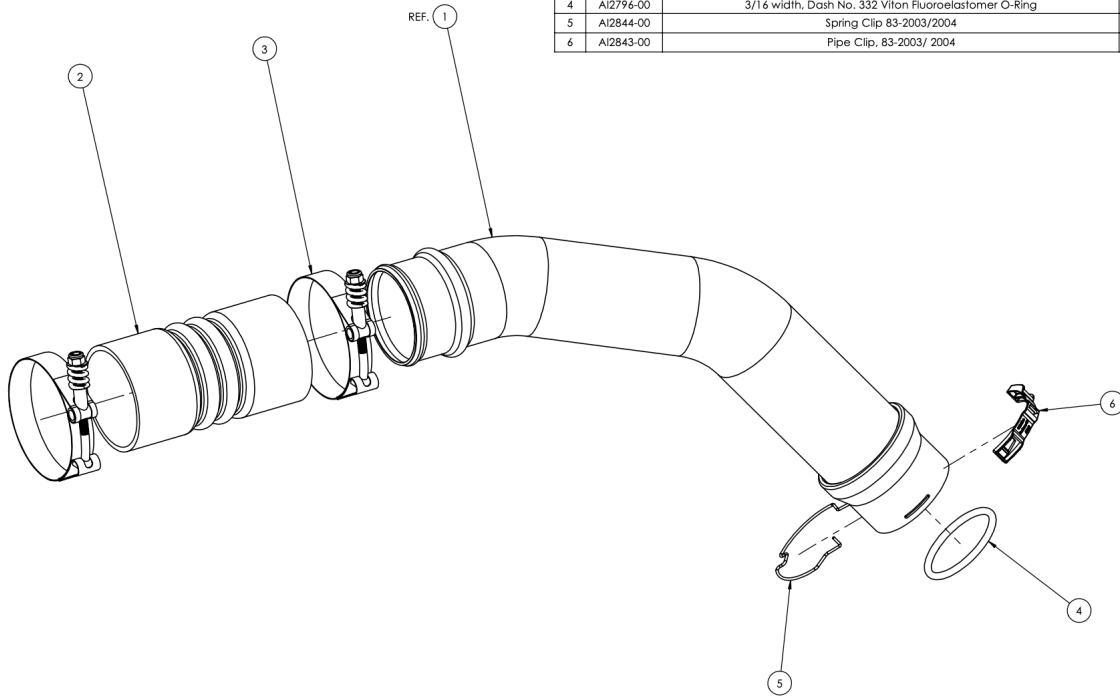

STEP 1

Start by loosening the hose clamp on the intercooler side.



STEP 2

Remove the clip on the top of the intercooler. To remove the

clip, pry up on the clip and slide it to the top of the retainer. Repeat for the bottom part of the clip.



STEP 3

Remove the stock intercooler pipe from the vehicle.



STEP 4

Slide the provided O-ring into the O-ring groove inside the pipe.



STEP 5

Install the S&B boot onto the intercooler with no hose clamp springs.



STEP 6

Install the new clip onto the S&B intercooler pipe.



STEP 7

With a 15mm, remove the sensor from the stock pipe and install onto the S&B pipe. The sensor is plastic so be careful to not overtighten on the S&B pipe.



STEP 8

Slightly slide the S&B intercooler onto the collar at the turbo.



STEP 9

Then connect the intercooler pipe to the boot. Using a flathead screwdriver to get the boot over the pipe end can help. After the boot is connected to the pipe, push the pipe onto the turbo. Make sure you hear a click sound when it connects.



STEP 10

Using an 11mm, remove the nuts on the springs in order to make them easier to install.



STEP 11

Once both hose clamp springs are broken down, install them onto the boot.



STEP 12

Once the hose clamp springs are installed on the boot, reinstall the springs and nuts then tighten down to 76 Inch-Pounds.



STEP 13

Install the Christmas tree clip into the bracket and reconnect the sensor.



CARB EO LABEL

Please affix the included CARB-approved EO label in an area under the hood. We recommend placing it on the radiator shroud, or the underside of the vehicle's hood near the S&B product.



Vehicle **CARB EO** Label Placement

Sample Label:



Locations:

Under Vehicle Hood

Radiator Shroud
(Preferred location)

