



**5476**  
**FRONT ANTI-SWAY BAR**  
**68-72 LEMANS, GTO, CHEVELLE, MALIBU, & EL CAMINO**

**CONGRATULATIONS!**

**You were selective enough to choose a BELLTECH PRODUCT. We have spent many hours developing our line of products so that you will receive maximum performance with minimum difficulty during installation.**

- Note:** Confirm that all of the hardware listed in the parts list is in the kit. **DO NOT** begin this installation if any part is missing. Read the instructions thoroughly before beginning this installation.
- Warning:** **DO NOT** work under a vehicle supported by only a jack. Place support stands securely under the vehicle in the manufacturer's specified locations unless otherwise instructed.
- Warning:** **DO NOT** drive the vehicle until all work has been completed and checked. Torque all hardware to values specified.
- Reminder:** Proper use of safety equipment and eye/face/hand protection is absolutely necessary when using these tools to perform procedures!
- Note:** It is very helpful to have an assistant available during the installation process.
- Note:** We **DO NOT RECOMMEND** using wheel ramps while performing this installation.

**RECOMMENDED TOOLS:**

- Properly rated floor jacks, support stands, and wheel chocks
- Combination wrench set
- Ratcheting socket wrench and socket sets
- Safety Glasses
- Air Ratchet

**KIT INSTALLATION**

1. Open the hardware kit and remove all of the contents. Refer to the part list (Page 3) to verify that all parts are present.
  2. Park the vehicle on a smooth, level concrete or seasoned asphalt surface and activate the parking brake. Block the REAR wheels of the vehicle with appropriate wheel chocks; making sure the vehicle's transmission is in 1<sup>st</sup> gear (manual) or "Park" (automatic).
  3. Using a properly rated floor jack, lift the front wheels of the vehicle off the ground. Place support stands, rated for the vehicle's weight, and in the factory specified locations. Refer to the vehicle Owner's Manual. Prior to lowering the vehicle onto the stands, make sure the supports will securely contact the chassis.
- !** It is very important that the vehicle is properly supported during this installation to prevent personal injury and chassis damage! Make sure that the supports stands are properly placed prior to performing the following procedures. We **DO NOT RECOMMEND** using wheel ramps while performing this installation.
4. This step is for vehicles with original equipment Anti-Sway Bars (ASB). Locate the end links at the ends of the Anti-Sway Bars (ASB) and disconnect them from the control arm. Locate and remove the bushing brackets from the center portion of the Anti-Sway Bar (ASB). Remove the original equipment Anti-Sway Bar (ASB).

5. Thoroughly lubricate the inside of your new hyper thane bushings using a high-grade lithium or silicone-based grease with molybdenum disulfide (moly). Place the bushings on the new Anti-Sway Bar (ASB). Refer to the original equipment Anti-Sway Bar (ASB) as to the proper bushing location. Place the bushing near the outermost bends of the bar on vehicles without original equipment Anti-Sway Bars (ASB).
6. Position the new Anti-Sway Bar (ASB) in the factory location and fasten the center portion with the brackets and bolts provided in kit. Space the Anti-Sway Bar (ASB) away from the car with the two flat plates under each bushing. See illustration.

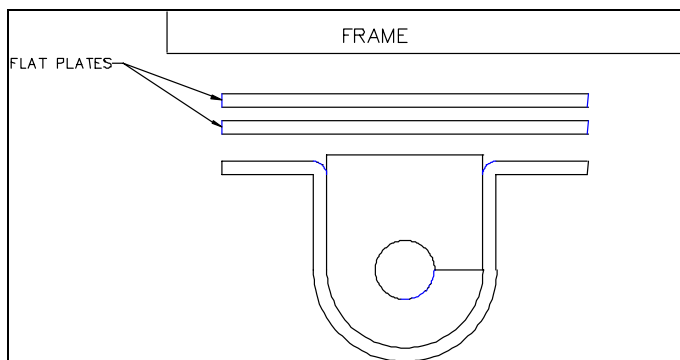

7. Connect the ends of the Anti-Sway Bar (ASB) to the control arms as shown in the diagram. Tighten the end links until the grommets bulge slightly, but **do not** crush them.
8. Check that all components and fasteners have been properly installed, tightened and torqued.
9. Check brake hoses, steering and other components for any possible interference.
10. Lift vehicle and remove support stands. Carefully lower vehicle to ground.
11. Immediately test-drive the vehicle in a remote location so that you can become accustomed to the revised driving characteristics and handling. Be aware that the vehicle will handle substantially different now that it has been modified.
12. Installation is complete. Check all of the hardware and re-torque at intervals for the first 10, 100, 1000 miles.

### PARTS LIST FOR 5476 ANTI-SWAY BAR KIT

PART No.	DESCRIPTION	QTY.
50065-300	Front ASB	1
110255	Nylon-Lock Nut 3/8-16	2
112140	3/8-16 x 7.0	2
112502	Cupped Washer Large	8
113000	End Link Grommet	8
112424	Spacer Tube 3/8" x 2-3/4"	2
113060	Pivot Bushing 1-1/4"	2
114022	Pivot Bushing Bracket	2
114038	Under Support Plate	4
112098	3/8-16 x 1-1/2 HHCS	4
112518	Flat Washer 3/8"	4
112078	5/16-18 x 1-1/4 HHCS	4
112024	10mm-1.5 x 30mm SHCS	4
55000-10	Grease Pack	1

## **! BELLTECH INSTALLATION TIPS**

### **LUBRICATION**

Pre-lubricating the inside of the bushing before it's installed is important because the lubrication will greatly reduce noise and it will increase bushing life. Belltech recommends you use Molybdenum disulfide. This will help protect the inside surface of the bushing and will last longer than most types of grease. Thoroughly lubricate the inside of the bushing with this grease.

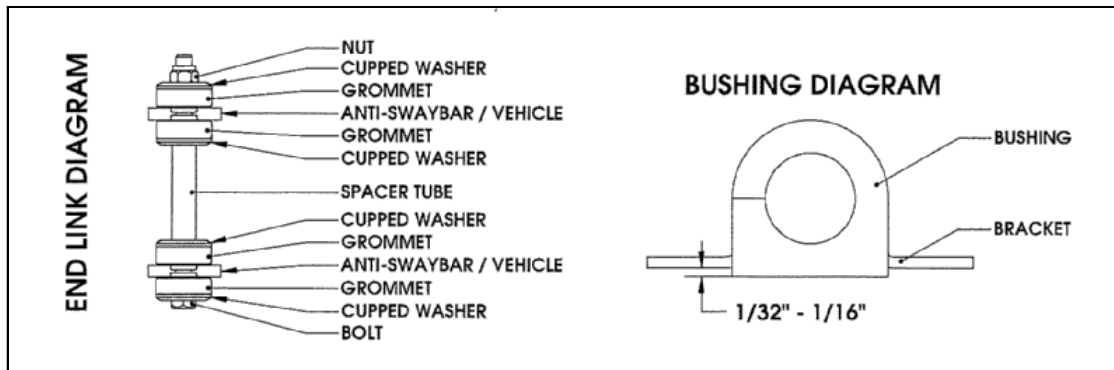

### **BUSHING INSTALLATION**

Make sure an amount of  $1/32''$  to  $1/16''$  of the bushing is showing when you install it onto the bracket. See the diagram above. If the bushing is showing more than  $1/16''$  than use a sander or a sheet of coarse grit sand paper to shave it down to the proper height. In most applications when installing the new bushings on your Belltech Anti-Sway Bar (ASB) you may refer to your original equipment Anti-Sway Bar to locate the proper location.

### **END LINK INSTALLATION**

It is not required that you use lubricant on the end links since there is no rotational movement. The Belltech end links are comprise of grommets, cupped washers, a spacer tube, bolt, and lock nut, these assembled components create the end link. See END LINK DIAGRAM above.