



INSTALLATION GUIDE

PART NUMBER: 25008 / 25012

FRONT LOWERING STRUT

GM COLORADO / CANYON 2WD / 4WD | 2015-2017

GM COLORADO / CANYON 2WD / 4WD | 2018-2020

0" TO -3" HEIGHT ADJUSTABLE LOWERING

300 W. PONTIAC WAY. CLOVIS, CA 93612

PHONE: 800-445-3767 | EMAIL: INFO@BELLTECH.COM

THANK YOU

Thank you for choosing our high quality Belltech product. We have spent a great deal of time developing our line of products so that you will receive maximum performance with minimal difficulty during installation. Soon your vehicle will be on the road looking and feeling much improved.

Please take a moment to read all instructions and warnings prior to the installation of your new Belltech product and before operating your vehicle. If you have any questions or concerns regarding any step in the installation process, please do not hesitate to call or email our customer support specialists who are trained to help you through any portion of this process.

Before You Begin:

It is of the utmost importance that you confirm all of the components listed on the parts list is in the kit. You can find this list located on the last page(s) of your instructions. Do not begin installation if any part is missing. Instead, please call our Belltech customer service specialists.

Belltech Customer Support:

Phone: 1-800-445-3767

Email: info@belltech.com

Safety Information:

Warning: Do not work under a vehicle supported only by a jack. Place support stands securely under the vehicle in the manufacturer's specified locations unless otherwise instructed.

Proper use of safety equipment and eye/face/hand protection is absolutely necessary when performing any of the following instructions.

We strive for an exceptional experience for all our valued customers. If for any reason you need assistance with your Belltech products, please do not return the product to the store you purchased from, but rather call our dedicated customer service experts, from 7am to 5pm PST.

We recommend that a qualified mechanic, at a properly equipped facility, perform this installation.

It is very helpful to have an assistant available during installation.

Before Driving Your Vehicle:

It is important to double check all brake hoses, cables, and other components to be sure there is no interference. You must also check for wheel/tire to chassis/body interference. If any issues are found, review your installation instructions to be sure no steps were missed and any problems are corrected.

Make sure your vehicle is aligned immediately following installation.

Check all hardware and re-torque at intervals for the first 10, 100, and 1000 miles.

Some of Belltech's products are designed to improve your vehicle's off-road performance. Leveling/lifting your vehicle may result in an altered center of gravity. It is crucial to use extreme care when operating your vehicle to prevent rollover and/or loss of control.

Any changes in your vehicle's suspension may result in transformed handleability. Please test-drive your vehicle in a remote location so you can become accustomed to the revised driving characteristics.

Perform headlight check and adjustment.

Failure to drive any modified vehicle in a safe manner may result in harm or death.

Never operate your modified vehicle under the influence of drugs, alcohol, or lack of adequate sleep.

Always wear your seatbelt.



DIFFICULTY:

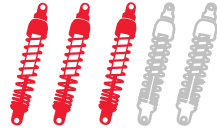

INSTALLATION TIME:

2-4 Hours + Alignment

RECOMMENDED TOOLS:

- Properly rated floor jack
- Support stands
- Wheel chocks
- Metric socket wrench set
- Metric wrench set
- Tape measure
- Marking Pen
- Safety glasses
- Spray paint

SPECIALTY TOOLS:

- High quality spring compressor
- Torque wrench up to 150 ft lbs.
- Abrasive cutter

INSTALLATION PREPARATION:

Before beginning the installation process, measure the hub to fender heights for your vehicle and record them in the “Before” section. After your vehicle has been modified, record the new measurements in the, “After” section. This way, you can compare the resulting height to the original. When taking the measurements, measure vertically from the center of the wheel to the inner edge of the fender.

Before:

LF: _____

RF: _____

LR: _____

RR: _____



After:

LF: _____

RF: _____

LR: _____

RR: _____

JACKING, SUPPORTING, AND PREPARING THE VEHICLE

1. Park your vehicle on a smooth, level, concrete or seasoned asphalt surface.
2. Block the rear wheels of the vehicle using wheel chocks. Make sure the vehicle's transmission is in "PARK" (automatic) or 1st gear (manual).
3. Activate the parking brake.
4. Break loose, but do not spin the wheel lug nuts to ease in removal when the wheels are in the air.
5. Lift the front of the vehicle off the ground using a properly rated floor jack. Lift the vehicle so the front tires are approximately 6-8 inches off the ground.
6. Place support stands rated for the vehicles weight. The stands should be positioned in the factory specified locations. (Refer to the owners manual). Prior to lowering the vehicle onto stands, make sure the support stands will contact the chassis. It is very important that the vehicle is properly supported to prevent any harm to ones self or to the vehicle.
7. Lower the vehicle slowly onto the stands.
8. Remove the front wheels.



Technician reminder:

Never work under a vehicle supported only by a jack. It is necessary to place support stands securely under the vehicle in the manufacturer's specified locations unless otherwise instructed.

OEM STRUT REMOVAL

9. Remove the guard from the lower center of the truck that covers the center section of the sway bar with a 15mm socket.
10. Remove the sway bar end links with a 13mm and 15mm wrench.
11. Remove the 10mm bolts securing the sway bar bushing brackets and remove the sway bar from the vehicle.
12. Remove the three upper 18mm bolts securing the strut assembly to the chassis.
13. Remove the 21mm lower mounting bolt.



14. Pry downward on the spindle and control arm assemblies; remove the strut assembly towards the rear of the vehicle. Ensure not to overextend or damage any brake lines or ABS lines during the removal. It may help to loosen the brake line bracket located just to the rear of the strut.

BUMP STOP MODIFICATION



Technician reminder:

Always use proper safety equipment while cutting metal. Also use precautions not to cause damage or fire from sparks or shavings. Belltech does not recommend the use of any type of flame cutting device for this process.

15. Detach the OEM bump stop from the OEM bump stop cup.
16. Cut the bump stop cup off using an abrasive cutting tool. Do not to damage any surrounding pieces during the cutting process.



BUMP STOP MODIFICATION CONTINUED

17. Grind the cut surface flat and remove any burrs. Paint all exposed metal surfaces to prevent corrosion.
18. Install the supplied Belltech bump stop using the existing hole in the chassis above the OEM bump stop cup.



OEM STRUT DISASSEMBLY

19. Mount the strut assembly in a spring compressor fixture. To ease the installation of the new strut, mark the position of the top mount in relationship to the upper spring isolator and strut body.



Technician note:

The installation photograph shown was taken at a professional installation shop. It is important to use a spring compressor to compress the spring before removing the top mount bolt. Failure to do so may result in serious injury.

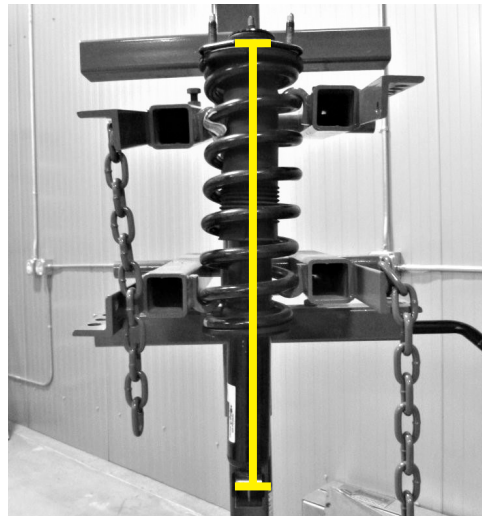

20. Compress the spring until tension is relieved from the strut.
21. Hold the strut shaft from spinning and remove the top center nut from the strut. Support the shock as the nut is removed as it will fall if not supported.
22. Remove top mount, upper spring isolator, and plastic lower spring isolator to use with your new Belltech strut later.
23. Separate the top mount from the spring isolator using a pry tool or flat head screw driver.
24. Remove the OEM strut from the compressed spring fixture.
25. Remove the plastic cap on top of the OEM strut body and the lower spring perch.



Technician reminder:

Removal of the lower spring perch may require significant force. Ensure not to damage the spring perch during the removal.

BELLTECH STRUT ASSEMBLY

26. The strut is delivered as shown below. Remove the Nyloc nut from the top of the Belltech strut to proceed



Technician note:

When lowering your vehicle more than -1", OE camber may not be achievable. Ensure proper toe alignment to minimize tire wear.

27. Using the tables below as reference, add the needed lift rings to reach the desired height.

2015-2020 GM COLORADO / CANYON 2WD / 4WD			
Drop (Inches)	8mm Ring	End Link	Hub to Fender Measurement "A"
0"	6	OEM	OEM
.5"	5	OEM	OEM
1"	4	OEM	19"
1.5"	3	OEM	19"
2"	2	BELLTECH	18"
2.5"	1	BELLTECH	18"
3"	0	BELLTECH	18"



Technician note:

The table above is designed to use Belltech strut with the OEM coil spring. Combining the Belltech strut with a lowering spring will require adjusting the ring quantities to adjust the total lowered spring height. Belltech does not recommend total lowering the vehicle beyond the lowest specification on this chart (3" total lowering) as the vehicle may not be able to be aligned and the performance of the shock may be greatly decreased.

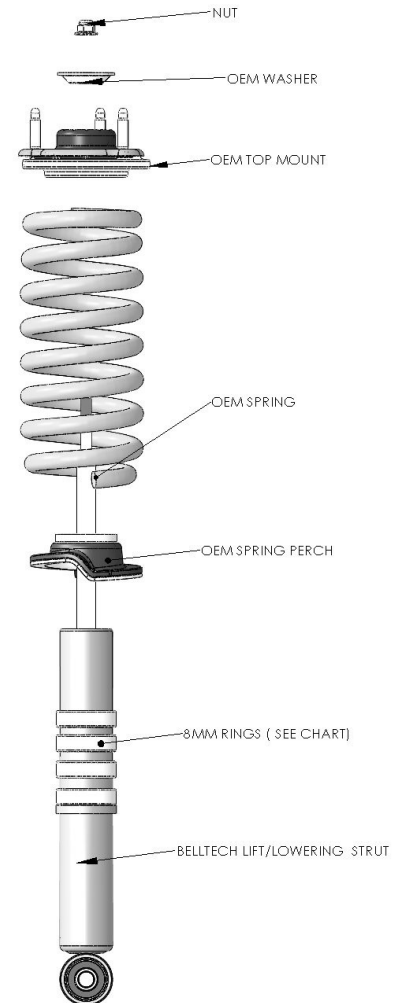

28. Install the OEM spring perch onto the strut. Do not install the spring perch upside down.
29. With the OEM spring still compressed, slide the new Belltech strut into the OEM spring.
30. Complete the assembly using the OEM spring isolator, top mount, and supplied Nyloc nut.
31. Align the top mount with the spring using the original marking made in step 13. Torque the strut rod nut to 33 ft lbs.

BELLTECH STRUT INSTALLATION

32. Loosen the upper control arm mounting bolts to release tension on the control arm bushings.

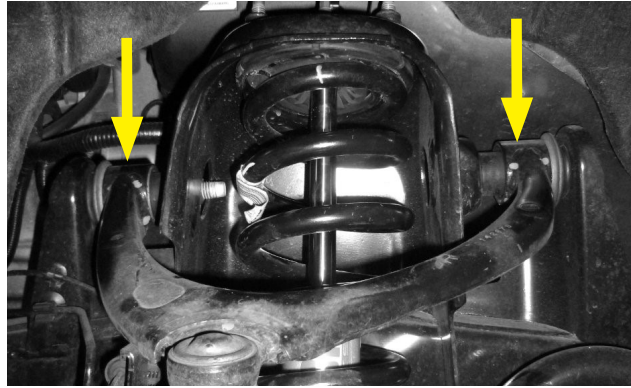

33. Referencing the chart on page 4, lift the control arm to the correct hub to fender preset for the desired drop.

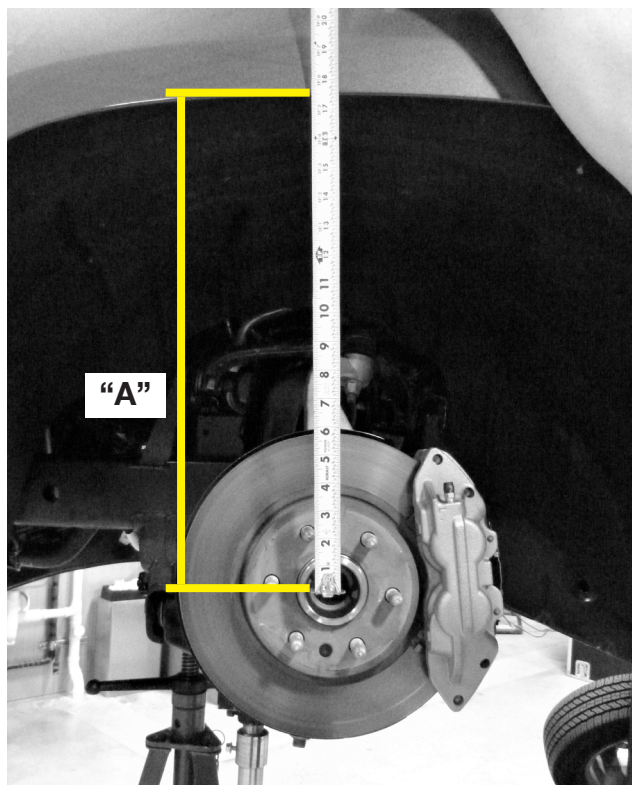

34. Tighten the control arm bushings with the correct hub-fender preset. Torque to 118 ft lbs.

35. Install the strut into position by prying downward on the control arm. Ensure not to cause damage to any of the brake or ABS lines. Insert the upper strut mount first and install the 3 nuts loosely to hold the strut in place.

36. Attach the lower strut mount to the lower control arm using the original bolt. Torque the three upper bolts to 43 ft lbs. and the lower mounting bolt to 74 ft lbs plus another 25-35 degrees.

BELLTECH STRUT INSTALLATION

37. Install the sway bar using the supplied end link. Referencing the chart on page 4, use the necessary end link to proceed. Torque the OEM end links (if used) to 22 ft lbs. Tighten the supplied Belltech end link (if used) until the grommets begin to bulge but do not crush them.

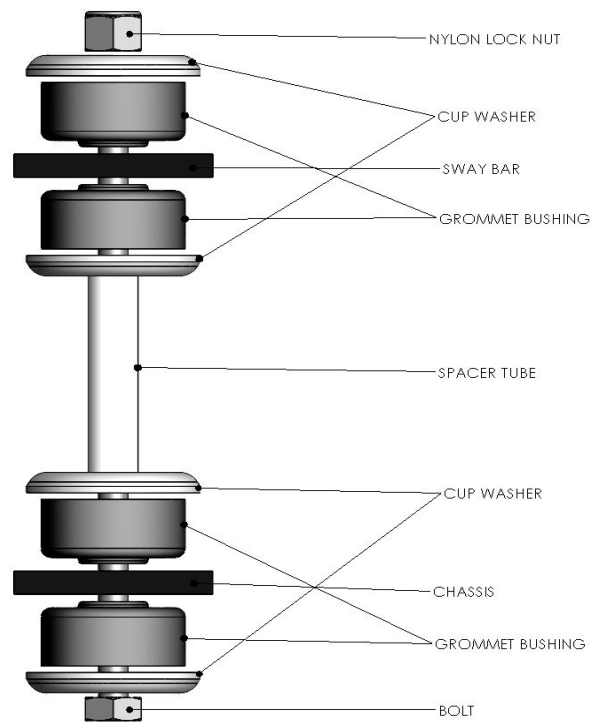

38. Mount the OEM guard below the sway bar and torque bolts to 18 ft lbs.
39. Check brake hoses and other components for any possible interference.

FINALIZING THE INSTALLATION

40. Mount the wheels and tighten the lug nuts.
41. Lift the vehicle and remove the support stands.
42. Carefully lower the vehicle onto the flat ground.
43. Torque the lug nuts to 140 ft lbs.
44. Check that all components and fasteners have been properly installed and torqued.
45. Read and perform all tasks in the “Before Driving Your Vehicle” section of page 1 of your instructions.

THANK YOU FOR CHOOSING BELLTECH.

You are now a part of the Belltech family and we are eager to catch a glimpse of your newly modified vehicle. Give us a shout out and let us know how much you love our product. Don't forget, we offer other Belltech related merchandise for you and your vehicle on our website www.belltech.com

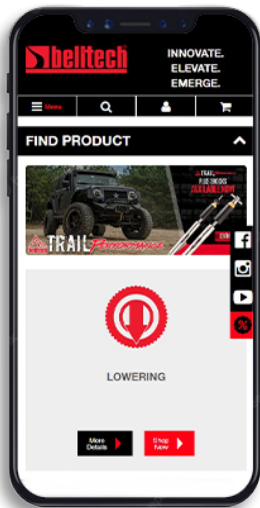

belltechsuspension



Belltech Suspension



@belltechsuspension

If you have any questions, concerns, or warranty related issues regarding your Belltech product, please call or email our experienced customer service specialists.

Belltech Customer Support:

Phone: 1-800-445-3767

Email: info@belltech.com

KIT CONTENTS 25008



25008		
Part number	Description	Qty
25008-100	BELLTECH LOWERING STRUT	1
25003-008	8MM LIFT RING	6
5922-001	BUMP STOP	1
25008-777	HARDWARE KIT	1

25008-777 Hardware Kit		
Part number	Description	Qty
113000	END LINK GROMMET	4
110255	NYLOC NUT	1
112138	HEX HEAD BOLT	1
112502	LARGE WASHER CUP	4
112420-95	SPACER TUBE	1

KIT CONTENTS 25012



25012		
Part number	Description	Qty
25008-100	BELLTECH LOWERING STRUT	1
25003-008	8MM LIFT RING	6
5922-001	BUMP STOP	1
25012-777	HARDWARE KIT	1

25012-777 Hardware Kit		
Part number	Description	Qty
113000	END LINK GROMMET	4
110255	NYLOC NUT	1
112140	HEX HEAD BOLT	1
112502	LARGE WASHER CUP	4
112428-95	SPACER TUBE	1